

PRIMAX

**PRODUCT
PERFORMANCE
PRIDE**

STEEL CENTERING SHUTTERING SCAFFOLDING EQUIPMENTS



ADJUSTABLE STEEL PROPS

Steel tubes are used for inner and outer of props. Adjustment vs safe axial load given below for standard type Props

Outer : 60.30 mm O.D. Inner : 48.30 O.D.

Size Prop.	Height M		Safe Axial Load Kg.	
	Closed	Extended	Closed	Extended
P1	1.10	1.75	3500	3000
P2	1.50	2.75	3200	2300
P3	2.00	3.25	3000	2200
P4	2.00	3.75	2900	2000
P5	3.00	4.65	2300	1150
P-Junior	2.00	3.10	1000	1500

Note : Props must be braced on both directions by tubes and Double Couplers at approximately 250 mm above Prop. Nut when extended beyond 3.75 M. The safe load so braced would be 2000 kg. Props with top U plate and also for Racking supports to wallform work available.



ADJUSTABLE FLOOR CENTRES/SPAN

These Spans are suitable for providing supports for Shuttering and can be used to economise on the requirement of individual Props. These Spans are of telescopic construction and consist of an outer and an inner member.

SIZE

LOADING TABLE

Model	SIZE		Slab thickness	Total Load including 180 Kg./Sq.m. for shuttering & Live load	Permissible Clear spans for centre line spacing			
	Min.	Max.			600 mm	800 mm	900 mm	1150 mm
ESO+ESI	175 cm	270 cm	125	480	5330	4650	4340	3760
SO+ESI	240 cm	345 cm	150	540	5000	4350	4090	3560
SO+SI	245 cm	412 cm	200	660	4520	3950	3680	3200
SO+LI	305 cm	475 cm	250	780	4140	3650	3380	2840
LO+SI	315 cm	485 cm	300	900	3730	3400	3150	2400
LO+LI	315 cm	550 cm						

Load table for various slab thickness and spans Overall lengths of span + 13 cm

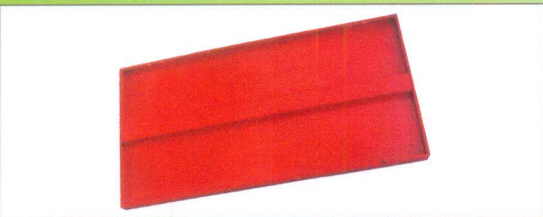

FLOOR FORMS/SLAB SHUTTERING

Floor Forms/Slab Shuttering are manufactured from 14/12 Gauge M. S. Sheets with pressed flanges and stiffeners with proper slots at the edges. Odd dimensions are filled up with the adjuster floor forms/slab shuttering.

Floor Form : 900x600 mm and 1150x600 mm Slab Shuttering : 900x600 mm and 1200x600 mm Other sizes are also available as per requirement.

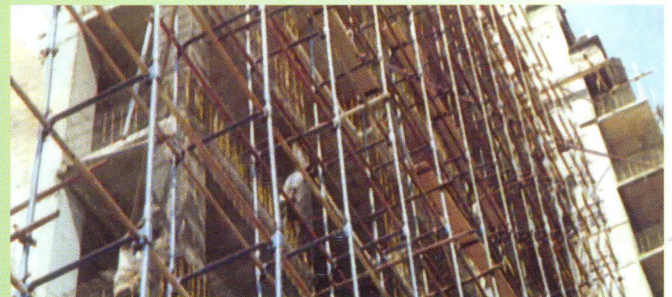

PRIMAX SCAFFOLDING SYSTEM

CUP LOCK SYSTEM

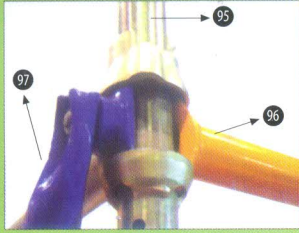

95 STANDARD (VERTICAL)	
HEIGHT	Kg
3.0M (9'10")	15.50
2.5M (8'2")	13.40
2.0M (6'6")	10.50
1.5M (4'11")	8.0
1.0M (3'3")	5.5
0.5M (1'7")	3.5
(1")	1.68

97 DIAGONAL BRACE	
LENGTH	Kg
10'	13.50
9'	12.23
8'	11.34
7'	10.43

96 LEDGER (HORIZONTAL)			
LENGTH	Kg	LENGTH	Kg
2.50M (8'2")	9.5	9'	10.66
1.80M (5'11")	7.0	8'	9.53
1.50M (4'11")	6.05	7'	8.35
1.25M (4'1")	4.9	6'	7.08
1.07M (3'6")	4.5	5'	6.12
0.90M (3')	4.3	4'	5.31
0.60M (2')	3.0	2'7"	4.13
(10')	11.8	1'10"	2.72

KWIKSTAGE SYSTEM

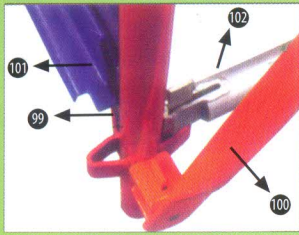

99 STANDARD (VERTICAL)	
HEIGHT	Kg
3.0M	19.12
2.5M	15.12
2.0M	12.74
1.5M	9.50
1.0M	6.91

100 DIAGONAL BRACE	
LENGTH	Kg
3.6M	9.94
2.1M	6.20
1.7M	5.50

102 LEDGER (HORIZONTAL)	
LENGTH	Kg
2.4M	10.1
1.8M	7.78
1.2M	5.51
0.7M	3.56

101 TRANSOM	
LENGTH	Kg
1.8M	15.98
1.2M	10.10
0.7M	0.7

U-FRAME / H-FRAME SCAFFOLDING

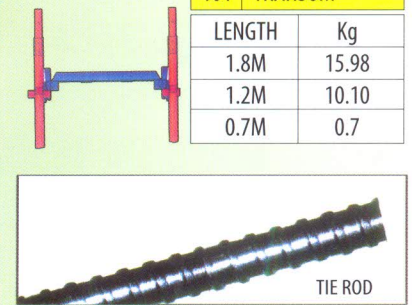
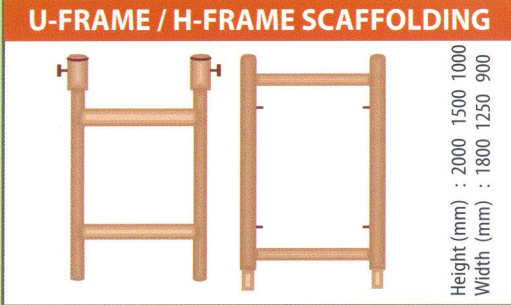
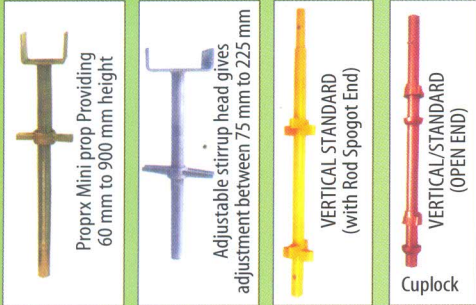

Height (mm) : 2000 1500 1000
Width (mm) : 1800 1250 900



WING NUT (Heavy/Medium/Light)



COUNTER PLATE



U-HEAD 8" x 8" 5.3 kg/8" x 9" 5.72 kg

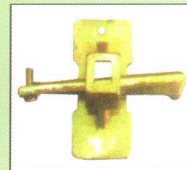

RAPID CLAMP

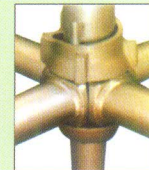

LEDGER

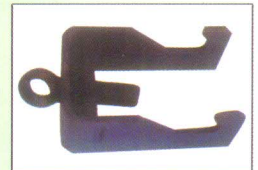

SINGLE CLAMP



TOP CUP



BOTTOM CUP



WATER STOPPER



LEDGER



GOGO CLAMP



ANCHOR NUT

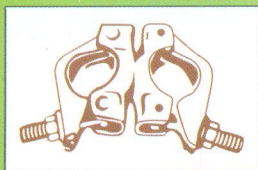

Swivel Coupler for any angle joint



Double Coupler for right angle joint



Fixed Base plate for 40 mm tube and spigot

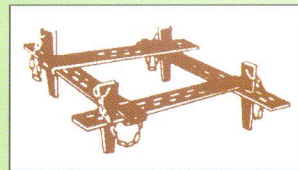

Adjustable column clamps are three sizes to accommodate column sizes from 150mm to 1370mm.

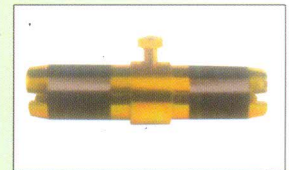

Expanding Joint Pin for connecting two tubes end to end



PRECON ENGINEERS

Head office :

12A, Netaji Subhas Road, Ground Floor, Kolkata - 700 001, India
Phone: (033) 2230 9544, 2230 2756, 2230 3188. Fax: (033) 2230 9544/3188

E-mail: info.primaxgroup@gmail.com, primaxequipment@gmail.com

Regd. office : Trenching Ground Road, Harinavi, Kolkata - 700148

Our Network : Assam, A. P., Andaman, Bihar, Chattisgarh, Jharkhand, Maharashtra, M. P., Mizoram, Orissa, Tripura