

PRIMAX
PRODUCT
PERFORMANCE
PRIDE



**SELF LOADING
CONCRETE MIXER**
CAPACITY : 2 & 4 M³



ACCREDITED[®]
Management System Certification MSCB-119

AN ISO 9001 : 2015 CERTIFIED CO.

Introduction

Great things transpire mind.

Inspiring machines are created engineering.

Primax Equipment Pvt. Ltd. infusing synergy to integrate the expertise for manufacturing the state of art construction equipment of international excellence to meet the growing demand for quality and efficient machineries in the infrastructure and the construction industry in India.



DIMENSIONS:-

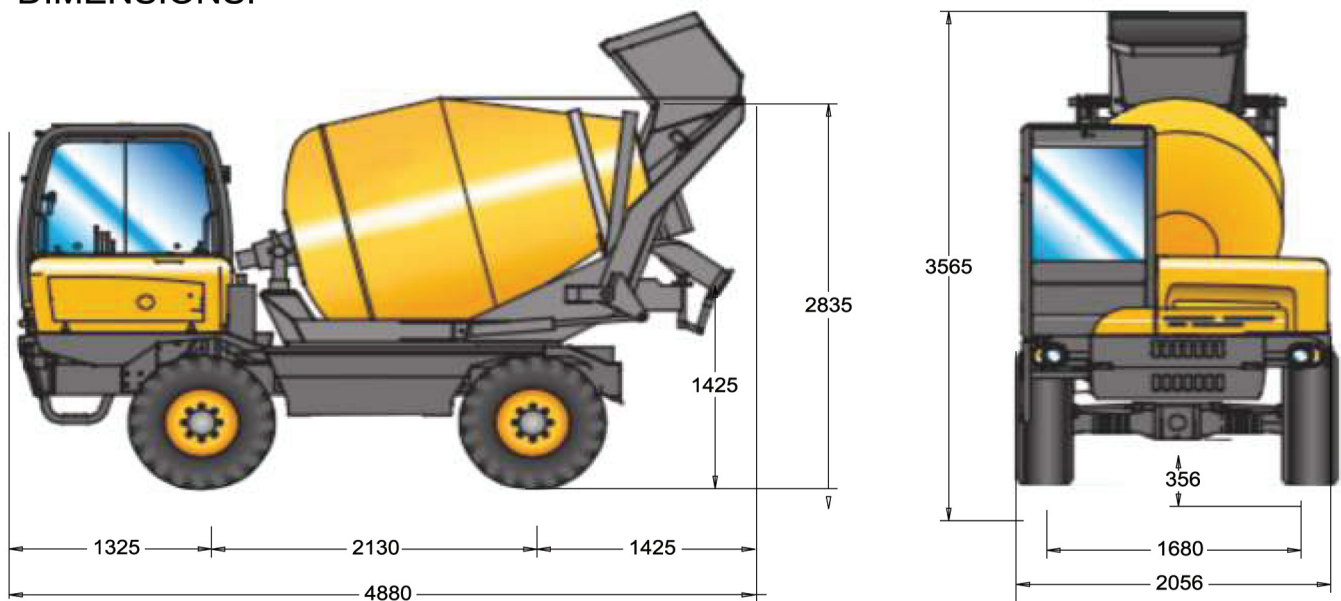

Digital Water Meter



Batch Counter with Printer



Turning Radius
3 Merers



Gradeability 30°



Steering Dashboard

PRIMAX Model - 2000, 4000

MODEL	PCM - 2000	PCM - 4000
DRUM CAPACITY	2 m ³	4 m ³
TYPICAL OUTPUT	6 - 8 cum/hr	10 - 12 cum/hr
SPEED	25 Kmph.	30 Kmph.
LOADING SHOVEL	550 ltrs.	750 ltrs.
GRADIENT	30°	29°
TYRES	12.5/80-18 12PR	405/70-20 14PR
ELCTRIC SYSTEM	12v DC, 130Ah	12v DC, 150Ah
BACKET CAPACITY	320 ltrs.	590 ltrs.
WATER TANK	2x250 ltrs.	2x300 ltrs.
DIESEL TANK	60 ltrs.	90 ltrs.
HYDRAULIC TANK	130 ltrs.	130 ltrs.
NET WEIGHT	5010 kgs.	7450 kgs.
GROSS WEIGHT	9810 kgs.	17050 kgs.
ENGINE		
Make	Kirloskar 4R 810T2	Kirloskar 4R 1040 T
Maximum power kw (hp)	60 hp	110 hp
Revolution per minute (rpm)	2400	2500
Operation	4 stroke diesel with Turbo	4 stroke diesel with Turbo
Number of cylinders	4	4
Cooling systems	Liquid cooling system	Liquid cooling system



TRANSMISSION : Hydrostatic, Bosch-Rexroth / Bondioli Pump and motor are connected to the differentials through a 2 speed reducer (working and transfer), 4 wheel driving and steering.



DRIVING SEAT : Reversible driver seat (180°) Adjustable seat with seat belt Front and rear windows with wipers.



CHASSIS : Steel profile specially engineered for off-road operations, box type construction.



CHUTE : Slewing and hydraulically tilting. Fitted with two pins easily detachable to increase the discharge height.



WATER SYSTEM : Self-contained. Hydraulic driven water pump, water meter, washing outlet. High pressure water pump.



BRAKES : Oil bath disc brakes inside differential axles. Twin independent circuits. Negative hydraulic parking brake.



STEERING : Hydrostatic on 4 wheels 4x4. Hydraulic power steering, 4 wheel steering for maneuvering in close paces.



CATALOGUES : PRIMAX is equipped with Use and Maintenance and Spare Parts Manuals according to CE regulations.

HIGH PERFORMANCE

- Compact Design for production of concrete inside the workplaces.
- Modern Technology and Imported quality components, to guarantee maximum reliability and performance.
- Simple to use.
- 4 x4, off road.
- Most Suitable for contractors looking for mechanized concrete production at minimal cost.
- Optimal Mix and high quality due to special drum configuration and its internal double screw together with Electronic batching system.
- High maneuverability, ease of operation and excellent road holding enables the vehicle to be positioned accurately and close to dumping site even on rough terrain.

COST REDUCTION & PRODUCTIVITY

- Increased productivity on construction sites due to on-site mixing.
- Only one operator is needed for driving, loading, dosage and mixing operations.
- On-site working minimises transportation and fuel costs thereby minimising the waste.
- On-site working reduces the use of other expensive machinery, such as, concrete pumps, transit mixers, cranes, dump trucks, etc.

SAFETY

- PRIMAX is always very sensitive to safety issues in the workplace.
- Our self loading mixers are designed and manufactured taking into account improved ergonomics of the driving position and are equipped with modern safety devices.



MINI MOBILE BATCHING PLANT (REVERSIBLE MIXER)



COMPACT CONCRETE BATCHING PLANT



PRIMAX EQUIPMENT PVT. LTD.

Head Office :

12A, Netaji Subhas Road, Ground Floor, Kolkata - 700 001, India

Phone : (033) 2230 9544 / 2230 2756

E-mail : info.primaxgroup@gmail.com, primaxequipment@gmail.com

Works : Mumbai Road, Domjur, Howrah - 711411, (W. B.)